

**IWAKI**  
**Gas-Liquid Transfer Pump**  
**APN-10/-20-W BLDC (built-in type)**  
**Instruction Manual**

 Read this manual before use of product

Thank you for selecting an IWAKI APN-10/-20-W gas-liquid transfer pump (BLDC motor). This instruction manual deals with "Safety Instructions", "Outline", "Installation", "Operation" and "Maintenance" sections.

Please read through this instruction manual to ensure the optimum performance, safety and service of your pump.

## Contents

<b>Safety Instructions</b> .....	<b>1</b>
<i>Outline</i>	
1. Unpacking & Inspection .....	3
2. Operating principle .....	3
3. Identification code .....	4
4. Specifications .....	4
5. Outer dimension .....	5
6. Performance curve .....	6
7. Overview & Label .....	7
8. Part names & Structure .....	7
<i>Installation</i>	
1. Before installation .....	8
2. Installation/Tubing/Electrical wiring .....	10
<i>Operation</i>	
1. Before operation .....	13
2. Pump operation .....	14
<i>Maintenance</i>	
1. Troubleshooting .....	15
2. Maintenance & Inspection .....	15
EC DECLARATION OF CONFORMITY .....	17



*This instruction manual should be kept on hand by the end user for quick reference.*

*Contact us or your nearest dealer if you have any questions.*



## Important Instruction

### For the Safe and Correct Handling of the Pump

- "Safety Instruction" section deals with important details about handling of the product. Before use, read this section carefully for the prevention of personal injury or property damage.
- Observe the instructions accompanied with "WARNING" or "CAUTION" in this manual. These instructions are very important for protecting pump users from dangerous situations.
- The symbols on this instruction manual have the following meanings:

 <b>WARNING</b>	<b>Nonobservance or misapplication of the contents of "Warning" section could lead to a serious accident which may result in death.</b>
 <b>CAUTION</b>	<b>Nonobservance or misapplication of the contents of "Caution" section could lead to personal injury or property damage.</b>

### Types of Symbols

	Indicates a prohibited action or procedure. Inside or near this circle, a concrete and practical image of the activity to be avoided is depicted.
	Indicates an important action or procedure which must be performed or carried out without fail. Failure to follow the instructions herein can lead to malfunction or damage to the pump.

### Export Restrictions

Technical information contained in this instruction manual might be treated as controlled technology in your countries, due to agreements in international regime for export control. Please be reminded that export license/permission could be required when this manual is provided, due to export control regulations of your country.

# Safety Instructions

## WARNING

- **Turn off power before service**

Risk of electrical shock. Be sure to turn off power to stop the pump and related devices before service is performed.



Electrical shock

- **Do not use the pump in any condition other than its intended purpose**

The use of the pump in any conditions other than those clearly specified may result in failure or injury. Use this product in specified conditions only.



Prohibited

- **Do not modify the pump**

Alterations to the pump carries a high degree of risk. It is not the manufacturer's responsibility for any failure or injury resulting from alterations to the pump.



No remodeling

- **Wear protective clothing**

Always wear protective clothing such as an eye protection, chemical resistant gloves, a mask and a face shield during disassembly, assembly or maintenance work.



Wear protectors

## WARNING

- **Use specified power only**

Do not apply power other than that specified on the nameplate. Otherwise failure or fire may result. Ensure the pump is properly grounded.



- **Do not damage the power cable**

Do not pull, knot, or crush the power cable. Damage to the power cable could lead to a fire or electrical shock if cut or broken.



Prohibited

- **Do not operate the pump in a flammable atmosphere**

Do not place explosive or flammable material near the pump.



Electrical shock

## CAUTION

- **Qualified personnel only**

The pump should be handled or operated by a qualified personnel with a full understanding of the pump.



- **Ventilation**

Fumes or vapours can be hazardous with certain solutions. Ensure proper ventilation at the operation site.



# Safety Instructions

## CAUTION

### • Do not install or store the pump:

1. Where ambient temperature falls below 5°C or exceeds 40°C.
2. Under a flammable/corrosive atmosphere.



Prohibited

### • Spill precautions

Ensure protection and containment of solution in the event of plumbing or pump damage (secondary containment).



### • Keep electric parts and wiring dry

Risk of fire or electric shock. Install the pump where it can be kept dry.



Prohibited

### • Do not use a damaged pump

Use of a damaged pump could lead to an electric shock or death.



Prohibited

### • Stop operation

If you notice any abnormal or dangerous conditions, suspend operation immediately and inspect/solve problems.



Electrical shock

### • Do not use the pump in a wet location

The pump is not waterproof. Use of the pump in wet or extremely humid locations could lead to electric shock or short circuit.



Prohibited

## CAUTION

### • Do not touch the pump or pipe with bare hands

Risk of burning. The surface temperature of the pump or pipe rises high along with liquid temperature in or right after operation.



Caution

### • Electromagnetic precautions

This product is not protected against an electromagnetic field. Take appropriate measures as necessary.



### • Damaged power cable

Do not use any damaged power cable for the prevention of a fire or electrical shock. The cable is not replaceable, so that the whole pump unit needs to be replaced when the cable is damaged.



Prohibited

### • Disposal of a used pump

Dispose of any used or damaged pump in accordance with local rules and regulations. If necessary, consult a licensed industrial waste disposal company.



### • Release the pressure from the discharge line

Solution in the discharge line may be under pressure. Release the pressure from the discharge line before disconnecting plumbing or disassembly of the pump to avoid solution spray.



# Outline

Before use, check the specification, limitation and hazardous nature of the pump.

## 1. Unpacking & Inspection

Open the package and check that the product conforms to your order. If any problem or inconsistency is found, immediately contact your distributor.

1. Check the nameplate to see if the information such as model codes, discharge capacity and discharge pressure are as ordered.

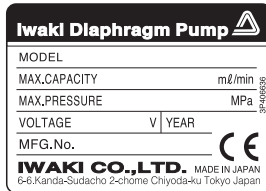

\*The CE marking on our product(s) is for us to market the product(s) into the European market, however, the CE marking does not ensure any safety or conformity of the product(s) outside the European market.

When the pump is incorporated into the equipment marketed in the European market, such equipment must meet all the requirements of applicable directives.

In such a case, any person who places the equipment on the market must carry a CE mark on the equipment as a manufacturer.

2. Check for transit damage, deformation and loose bolts.

## 2. Operating principle

The APN-10/-20-W is a gas-liquid transfer pump with a small size diaphragm.

The rotary motion of the motor is converted via a connecting rod to the reciprocation of the diaphragm in the pump chamber, where the mixture of gas and liquid is transferred from the inlet to outlet.

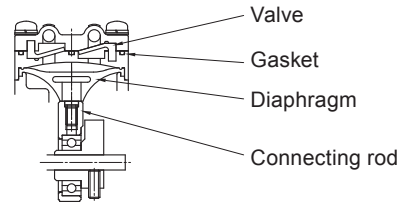

# Outline

## 3. Identification code

**APN - 10 E D3 - W 02**  
 a b c d e

### a. Series name

10 : APN-10

20 : APN-20

### b. Valve/Gasket materials

No code : FKM

E : EPDM

### c. Rated voltage

D3 : 24V BLDC

### d. Gas-liquid transfer type

### e. Special specification

No code : Standard

01-99 : Special design

## 4. Specifications

### ■ Pump

Type	Gas transfer			Liquid transfer		24VDC	Conne- ction Tube ID	Weight (g)
	Max. air flow (ml/min)	Max. discharge pressure (MPa)	Max. vacuum (kPa)	Max. liquid flow (ml/min)	Max. discharge pressure (MPa)			
APN-10	200	0.03	74.66	180	0.1	0.3	ø4.5 ø5.0	200
APN-20				260				

NOTE 1. Allowable maximum allowable discharge pressure is 0.03MPa.

NOTE 2. The max liquid flow is based on the operation with clean water at 20°C and may change with liquid temperature, viscosity and specific gravity.

NOTE 3. Allowable gas temperature range is 5-40°C.  
 Allowable liquid temperature range is 10-40°C.

NOTE 4. Allowable ambient temperature range is 5-40°C.

NOTE 5. Allowable maximum noise level is 54dB at 1m (A scale) with clean water at 20°C.

### ■ Wet end material

Parts	Materials	
	FKM type	EPDM type
Pump head	GFRPP	
Diaphragm	PTFE/EPDM (EPDM is not a wet end)	
Valve	FKM	EPDM
Valve seat	GFRPP	
Gasket	FKM	EPDM

GFRPP: Glass fibre reinforced polypropylene

PTFE: Polytetrafluoroethylene

EPDM: Ethylene propylene diene monomer

FKM: Fluorine-contained rubber

## 5. Outer dimension

### ■ APN-10/-20-W BLDC

Dimension in mm

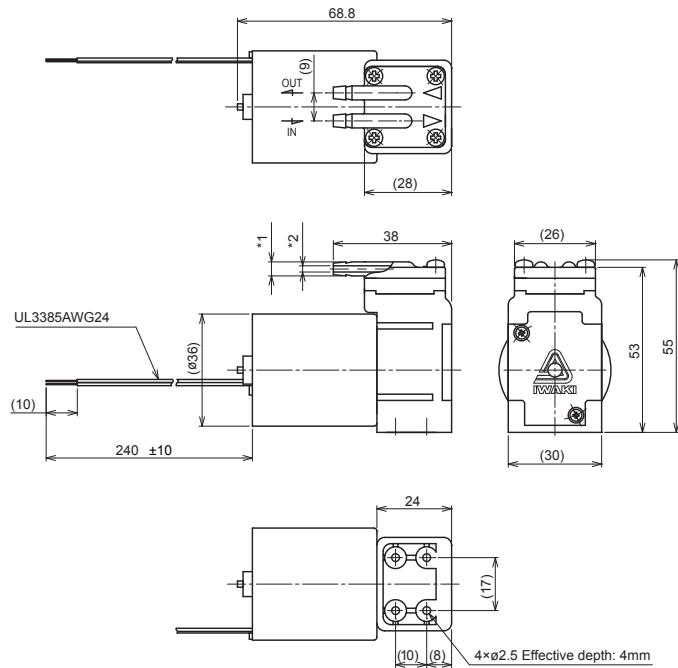

\*1 APN-10-W BLDC: φ4.5

APN-20-W BLDC: φ5.0

\*2 APN-10-W BLDC: φ2.0

APN-20-W BLDC: φ2.5

## 6. Performance curve

Gas transfer (with ambient air at 20°C)  
<APN-10/-20-W>

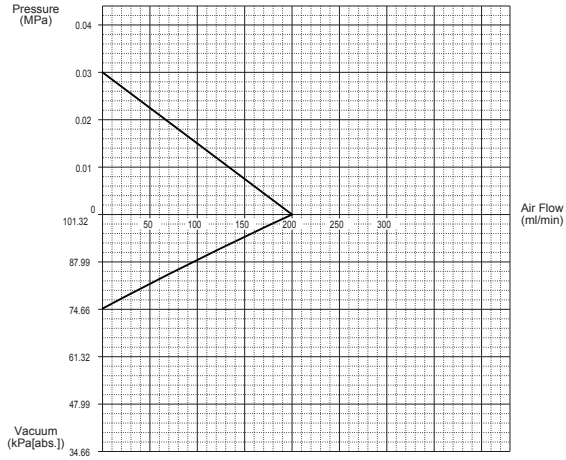

Liquid transfer (with clean water at 20°C)  
<APN-10-W>

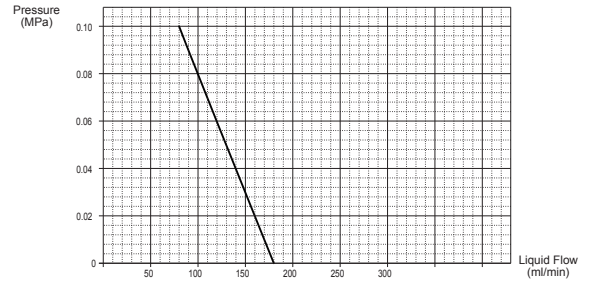

<APN-20-W>

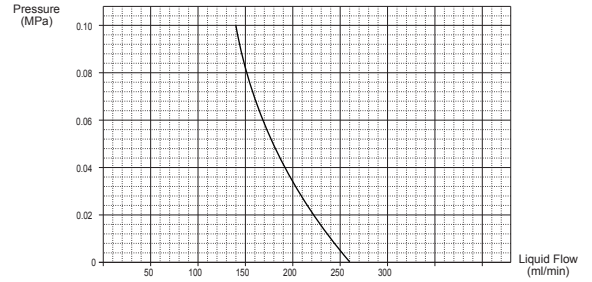



## 7. Overview & Label

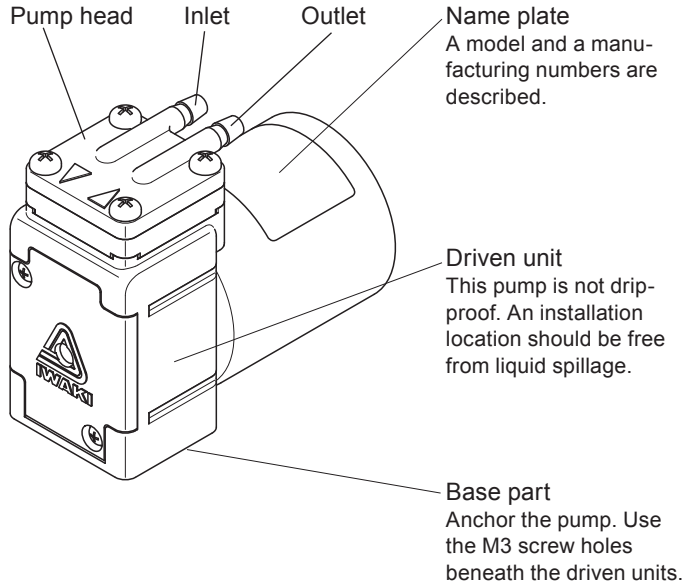

## 8. Part names & Structure

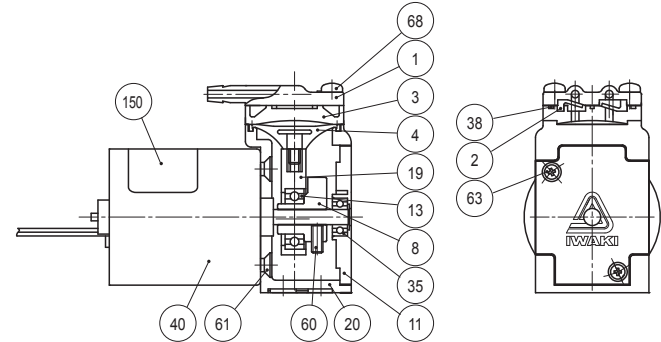

No.	Part names	Q'ty
1	Pump head	1
2	Valve	2
3	Valve seat	1
4	Diaphragm	1
8	Eccentric cam	1
11	Bracket cover	1
13	Bearing	1
19	Connecting rod	1
20	Bracket	1

No.	Part names	Q'ty
35	Bearing	1
38	Gasket	1
40	Motor	1
60	Set screw (M3×8)	2
61	Screw (M3×6)	2
63	Screw (M2×6)	2
68	Screw (M3×16)	4
150	Name plate	1

# Installation

## 1. Before Installation

Read through this instruction manual before use. Carry out installation work with a full understanding.

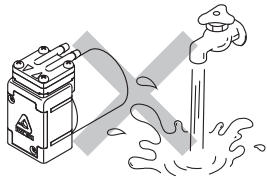

- Install the pump where it can be kept dry.

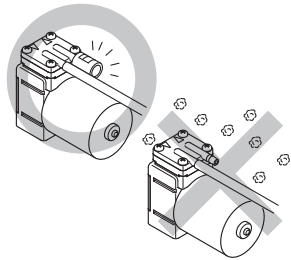

- Do not use the pump in a dusty place. Be sure to provide the inlet with a filter to prevent foreign matters from getting into the pump. Otherwise, the pump performance may reduce or the lives of the valve and diaphragm may remarkably shorten.

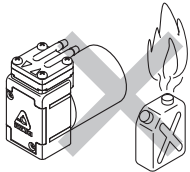

- Do not install the pump in a corrosive or flammable gas atmosphere. Keep good ventilation in a working area. Ambient temperature should not fall below 5°C or exceed 40°C. Observe the allowable gas temperature range of 5 and 40°C and liquid temperature range of 10 and 40°C.

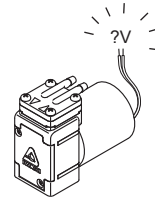

- Observe the rated voltage specified on the nameplate. Applying any voltage than the rated one may result in failure.

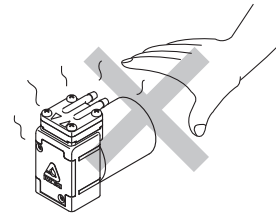

- Surface temperature may rise high in operation. Do not touch the pump body directly or place the objects which may be deformed by heat close to the pump.



- Solution in the discharge line may be under pressure. Release the pressure from the discharge line before disconnecting plumbing or disassembly of the pump to avoid solution spray.

## *Installation*

---

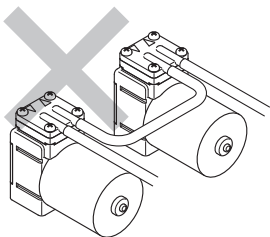

- Do not tube two or more pumps in series. It may prevent the motor from starting and lead to a burnout, or may damage the diaphragm or tubing.

# Installation

## 2. Installation/ Tubing/ Electrical wiring

### **WARNING**

If you notice any abnormal or dangerous conditions, suspend operation immediately and inspect/solve problems.

### 2.1 Installation

#### 1. Installation location

This pump is designed to be built into equipment under proper protection.

- Do not install the pump in direct sunlight, wind & rain or mechanical vibration.
- Select a level location, free from vibration, that won't hold liquid.
- Keep good ventilation. The pump should always be free from the possibility of getting wet.
- Ambient temperature should not fall below 5°C or exceed 40°C.
- Ambient humidity should not fall below 35%RH or exceed 90%RH.
- Allow sufficient space around the pump for easy access and maintenance.

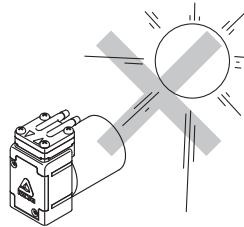

#### 2. Pump fixation

Tighten the 3mm O.D. tapping screws by 0.3N•m to anchor the pump on a basis.

### **CAUTION**

**Do not install the pump on an unstable place.**

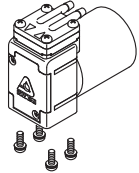

### 2.2 Tubing

#### 1. Before tubing

The short tubing with the minimum bends is optimal to reduce resistance.

### **CAUTION**

**Do not have tubing bent or pressed. Otherwise, the tube end may break.**

#### 2. Tube preparation

- Cut the tube ends flat beforehand.
- Use chemically-resistant tubes or temperature-/pressure-resistant tubes as necessary.

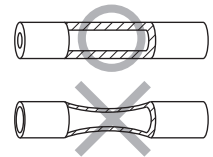

# Installation

---

---

- When the pump is used for the delivery of liquid, use a suction line of 4mm I.D. to give a certain resistance to an incoming flow for the prevention of an overloaded/locked motor, and a discharge line of 4mm O.D. to maintain a certain amount of outgoing flow and assures the rated pump performance will be kept.

### 3. Tube connection

Push the tubes into the inlet and outlet as far as they will go. Use tube bands to make sure tubes are fastened as necessary.

NOTE: If the suction line connection is imperfect, the pump entrains air and so the full performance will not be achieved.

### 4. Connection checkout

Check that a suction line is connected to the inlet and a discharge line is connected to the outlet.

#### CAUTION

**If a suction line and a discharge line are connected the other way around, pumping process is inverted.**

### 5. Valve mounting

Install a valve in a suction line between the pump and a supply tank for adjusting an air/liquid flow and the degree of vacuum.

### 2.3 Electrical wiring

*Electrical wiring must be performed by a qualified electrician. It is not the manufacture's responsibility for personal injury or property damage resulting from unauthorized service. Contact us or your nearest distributor for wiring as necessary.*

#### ■ Before wiring

1. Check that the main power is turned off.
2. Electrical work should be performed in accordance with local electric codes, with an appropriate wire gauge or so.
3. Apply the specified power voltage. See the spec label.
4. This product is not protected against an electromagnetic field. Take appropriate measures as necessary.
5. After wiring work, check that the system is free from the inductive noise at start-up.
6. The drive circuit generates noise because of its high-speed switching. Check if peripheral devices are not affected by the noise.
7. This product, especially for the motor PCB, is not protected against (and therefore breaks at) the occurrence of a high voltage spike such as a lightning surge. Use a varistor as necessary.
8. When an earth leakage breaker is used and has tripped, always investigate and solve root causes. Be sure to unplug the pump before investigation is performed.

# *Installation*

---

## ■ Wiring

### *1. Power lead polarity*

The red power lead leading from the pump is positive polarity and must be connected to a positive contact of a DC power supply, and the black power lead leading from the pump is negative polarity and must be connected to a negative contact of the DC power supply. Or motor failure may result.

### *2. External fuse*

Install an external fuse in the power line for overcurrent protection.

# Operation

## 1. Before operation

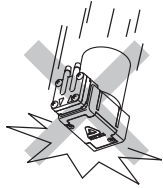

- Use care handling the pump. Do not drop. An impact may affect pump performance.

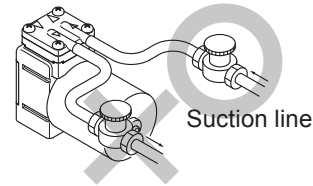

- Always use a suction valve to adjust an air/liquid flow.



- The pump can not start with full discharge/suction pressure or liquid. Remove pressure or liquid before operation.

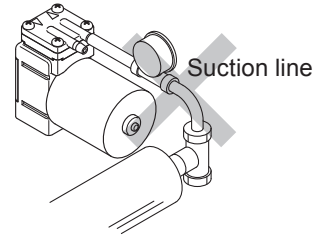

- If the compressed air or liquid (higher pressure than atmospheric pressure) is transferred to the pump, sharp deterioration to the lives of the valve, diaphragm and bearing may result. Always keep atmospheric or lower pressure in the suction line.



- After a long period of stoppage, pump performance at the beginning of operation becomes occasionally unstable. In this case, warm the pump up for 10 minutes with no discharge line pressure.



Prohibited

- Do not use solvents such as benzene, alcohol, thinner for maintenance or cleaning, otherwise a coat discolours or comes off.



Prohibited

- Do not close discharge line during operation. The pump and tubing may be damaged. Always observe the allowable maximum discharge pressure.

# Operation

## 2. Pump operation

### ■ Operation

Operate the pump according to the following steps.

No.	Procedure	Points to be Checked
1	Check tubing, wiring and voltage.	<ul style="list-style-type: none"><li>● Check installation, tubing and wiring are properly done and wiring system is fused.</li><li>● Check the spec label to see if power supply voltage is correct.</li></ul>
2	Open valves.	<ul style="list-style-type: none"><li>● Fully open both discharge and suction lines.</li></ul>
3	Supply power to the pump.	<ul style="list-style-type: none"><li>● Smooth starting may not be obtained when ambient temperature is 10°C or below. In this case, run the pump with no discharge line pressure for a few minutes to warm it up.</li><li>● Smooth starting may not be obtained when the pump chamber is filled with liquid. Get rid off liquid before operation.</li></ul>
4	Adjust a liquid/air flow.	<ul style="list-style-type: none"><li>● Provide a running-in period (about 10 minutes) before full scale operation.</li><li>● Always adjust a liquid/air flow by a suction valve.</li></ul>
5	Check the operation.	<ul style="list-style-type: none"><li>● After starting, check a pressure gauge to see if suction and discharge line pressure are correct and an air flow meter to see if the specified air flow is obtained.</li><li>● Keep a suction line pressure at or below atmospheric pressure.</li><li>● In case electric power has failed while the pump is running, switch off main power. Otherwise, the motor may not re-start or may burn out depending on a line pressure at the time of power recovery.</li></ul>

### ■ Stop and Storage

- Before a long period of stoppage (1 week or more):  
Depressurize/empty the pump. Some liquids may harden or crystallize when they are left for a long time. In this case clean wet ends before/after operation.
- Do not store the pump:
  - Where ambient temperature can exceed 5-40°C.
  - In a dusty/humid environment.
  - In a flammable/corrosive atmosphere.
  - Under mechanical vibration or wind & rain.



# Maintenance

## 1. Troubleshooting

**If you notice any abnormal or dangerous conditions, suspend operation immediately and inspect/solve problems. Contact us or your nearest distributor as necessary.**

Phenomenon					Measures
Causes	Pump does not run.	Pump stops running.	Poor air flow or discharge pressure	Pump makes noise.	
No power distribution	<input type="radio"/>	<input type="checkbox"/>	<input type="checkbox"/>	<input type="checkbox"/>	Check wiring.
Motor trouble (disconnection)	<input type="radio"/>	<input type="radio"/>	<input type="checkbox"/>	<input type="checkbox"/>	Replace the pump.
Wrong tubing or poor connection	<input type="radio"/>	<input type="checkbox"/>	<input type="radio"/>	<input type="checkbox"/>	Check and fix tubing.
Pump head mounting screws are loose.	<input type="checkbox"/>	<input type="checkbox"/>	<input type="radio"/>	<input type="radio"/>	Tighten the screws.
Diaphragm insertion is loose.	<input type="radio"/>	<input type="radio"/>	<input type="radio"/>	<input type="radio"/>	Tighten diaphragm.
Diaphragm is damaged.	<input type="checkbox"/>	<input type="checkbox"/>	<input type="radio"/>	<input type="radio"/>	Replace the pump.
Filter is clogged.	<input type="checkbox"/>	<input type="checkbox"/>	<input type="radio"/>	<input type="checkbox"/>	Remove foreign matters.
Valves are worn.	<input type="checkbox"/>	<input type="checkbox"/>	<input type="radio"/>	<input type="checkbox"/>	Replace the pump.
Front cover fixing screws are loose.	<input type="checkbox"/>	<input type="checkbox"/>	<input type="radio"/>	<input type="radio"/>	Secure them.
Eccentric shaft has worn.	<input type="radio"/>	<input type="checkbox"/>	<input type="checkbox"/>	<input type="radio"/>	Replace the pump.
Connecting rod bearing has worn.	<input type="radio"/>	<input type="radio"/>	<input type="checkbox"/>	<input type="radio"/>	Replace the pump.
Motor bearing has worn.	<input type="radio"/>	<input type="radio"/>	<input type="checkbox"/>	<input type="radio"/>	Replace the pump.
Voltage reduction	<input type="radio"/>	<input type="radio"/>	<input type="checkbox"/>	<input type="checkbox"/>	Increase voltage to the rated level.
Higher suction pressure than atmospheric	<input type="radio"/>	<input type="radio"/>	<input type="checkbox"/>	<input type="checkbox"/>	Reduce suction pressure.

## 2. Maintenance & Inspection

**Handling of the pump, maintenance and inspection should be carried out within the descriptions of this instruction manual.**

**It is not the manufacturer's responsibility for personal injury or property damage resulting from unauthorized service. Contact us or your nearest distributor as necessary.**

### ■ Daily inspection

Check the following points every day. If you notice any abnormal or dangerous conditions, suspend operation immediately and remove problems according to the troubleshooting section, or contact your distributor for detail.

No.	Check that:	Measure
1	pump operation is normal.	<ul style="list-style-type: none"> <li>• Apply correct voltage and amperage.</li> <li>• Adjust discharge/suction pressure.</li> </ul>
2	there is no noise or vibration problem.	<ul style="list-style-type: none"> <li>• Unusual noise/vibration may occur when pump operation is not normal.</li> </ul>
3	there is no air leak or air ingress from pump parts and tubing connections.	<ul style="list-style-type: none"> <li>• Retighten connections.</li> </ul>

# Maintenance

---

---

## ■ Pump replacement

Replace the pump at the end of life span or when performance has remarkably reduced.

Conditions	Part names	Pump
<gas transfer> 0.03MPa or below (pressurization) or 74.66KPa (abs.) or below (vacuum)		4000hr
<liquid transfer> 0MPa		4000hr
<liquid transfer> 0.1MPa or below (pressurization)		2500hr

\*Part lives vary with the pressure, temperature and character of gas/liquid. Values on the above table are collected in continuous operation at the rated voltage and 20°C ambient temperature with 20°C gas or gas-liquid mixture.

# EC DECLARATION OF CONFORMITY

A copy of the original Declaration of Conformity

(SUPPLIER'S NAME)

WE  
IWAKI CO.,LTD.

(ADDRESS)

6-6 2-CHOME KANDA-SUDACHO CHIYODA-KU TOKYO JAPAN

(PRODUCT)

DECLARE UNDER OUR SOLE RESPONSIBILITY THAT THE PRODUCTS  
AIR PUMP

(MODEL NAME)

APN-W SERIES DC TYPE

TO WHICH THIS DECLARATION RELATES ARE IN CONFORMITY  
WITH THE FOLLOWING STANDARDS OR DIRECTIVES AS FAR AS APPLICABLE

(DIRECTIVES)

MACHINERY DIRECTIVE 2006/42/EC (ANNEX IIA)  
RoHS DIRECTIVE 2011/65/EU

(STANDARDS)

EN ISO12100:2010      EN809:1998+A1:2009      EN IEC63000:2018

(A PERSON WHO IS AUTHORISED TO COMPILE THE TECHNICAL FILE  
IN THE COMMUNITY)

IWAKI EUROPE GMBH  
SIEMENSRING 115 D-47877 WILLICH GERMANY

NOTE: THIS DECLARATION BECOMES INVALID IF TECHNICAL OR OPERATIONAL  
MODIFICATIONS ARE INTRODUCED WITHOUT THE MANUFACTURER'S  
CONSENT.



TSUTOMU SAWADA  
DEPUTY SENIOR GENERAL MANAGER,  
QUALITY ASSURANCE HEAD OFFICE

Tokyo, Sep. 13, 2021

(PLACE AND DATE OF ISSUE)

(NAME AND SIGNATURE OR EQUIVALENT MARKING OF AUTHORIZED PERSON)

DOCUMENT NO. IS-51K-538-3



<https://www.iwakipumps.jp>  
IWAKI CO.,LTD. 6-6 Kanda-Sudacho 2-chome Chiyoda-ku Tokyo 101-8558 Japan  
TEL: +81 3 3254 2935 FAX: +81 3 3252 8892

**European office** / IWAKI Europe GmbH  
TEL: +49 2154 9254 0 FAX: +49 2154 9254 48

**Germany** / IWAKI Europe GmbH  
TEL: +49 2154 9254 50 FAX: +49 2154 9254 55

**Holland** / IWAKI Europe GmbH (Netherlands Branch)  
TEL: +31 74 2420011 FAX: +49 2154 9254 48

**Italy** / IWAKI Europe GmbH (Italy Branch)  
TEL: +39 0444 371115 FAX: +39 0444 335350

**Spain** / IWAKI Europe GmbH (Spain Branch)  
TEL/FAX: +34 934 741 638

**Poland** / IWAKI Europe Branch EAST  
TEL: +48 12 347 0755 FAX: +48 12 347 0900

**Belgium** / IWAKI Belgium N.V.  
TEL: +32 13 670200 FAX: +32 13 672030

**Denmark** / IWAKI Nordic A/S  
TEL: +45 48 242345

**Finland** / IWAKI Suomi Oy  
TEL: +358 10 201 0490

**France** / IWAKI France S.A.  
TEL: +33 1 69 63 33 70 FAX: +33 1 64 49 92 73

**Norway** / IWAKI Norge AS  
TEL: +47 23 38 49 00

**Sweden** / IWAKI Sverige AB  
TEL: +46 8 511 72900

**U.S.A.** / IWAKI America Inc.  
TEL: +1 508 429 1440 FAX: +1 508 429 1386

**Argentina** / IWAKI America Inc. (Argentina Branch)  
TEL: +54 11 4745 4116

**Brazil** / IWAKI Do Brasil Comercio De Bombas Hidraulicas LTDA.  
TEL/FAX: +55 19 3244 5900

**Singapore** / IWAKI Singapore Pte Ltd.  
TEL: +65 6316 2028 FAX: +65 6316 3221

**Indonesia** / IWAKI Singapore (Indonesia Office)  
TEL: +62 21 6906606 FAX: +62 21 6906612

**Malaysia** / IWAKIm SDN. BHD.  
TEL: +60 3 7803 8807 FAX: +60 3 7803 4800

**Australia** / IWAKI Pumps Australia Pty Ltd.  
TEL: +61 2 9899 2411 FAX: +61 2 9899 2421

**China (Hong Kong)** / IWAKI Pumps Co., Ltd.  
TEL: +852 2607 1168 FAX: +852 2607 1000

**China (Guangzhou)** / GFTZ IWAKI Engineering & Trading Co., Ltd.  
TEL: +86 20 84350603 FAX: +86 20 84359181

**China** / IWAKI Pumps (Shanghai) Co., Ltd.  
TEL: +86 21 6272 7502 FAX: +86 21 6272 6929

**Korea** / IWAKI Korea Co., Ltd.  
TEL: +82 2 2630 4800 FAX: +82 2 2630 4801

**Taiwan** / IWAKI Pumps Taiwan Co., Ltd.  
TEL: +886 2 8227 6900 FAX: +886 2 8227 6818

**Thailand** / IWAKI (Thailand) Co., Ltd.  
TEL: +66 2 322 2471 FAX: +66 2 322 2477